



**1.25G SFP Transceiver 1000BaseFX LR 1310nm**  
(PN: MWS-12-31-10D / MWS-12-31-20D / MWS-12-31-40D)



**Features:**

- ✧ Up to 1.25Gb/s Data Links
- ✧ Hot-Pluggable
- ✧ 1310nm FP laser transmitter
- ✧ Duplex LC connector
- ✧ RoHS compliant and Lead Free
- ✧ Up to 20 km on 9/125  $\mu$  m SMF
- ✧ Single +3.3V Power Supply
- ✧ Monitoring Interface Compliant with SFF-8472
- ✧ Low power dissipation <1W typically
- ✧ Commercial operating temperature range: 0°C to 70°C

**Applications:**

- ✧ Metro/Access Networks
- ✧ 1.25 Gb/s 1000Base-LX Ethernet
- ✧ 1×Fiber Channel
- ✧ Other Optical Link

**Description:**

**MWS-12-31-XXD** Transceiver is a high performance, cost effective module which have a Duplex LC optics interface. Standard AC coupled CML for high speed signal and LVTTTL control and monitor signals.



**1.25G SFP Transceiver 1000BaseFX LR 1310nm**  
**(PN: MWS-12-31-10D / MWS-12-31-20D / MWS-12-31-40D)**

The receiver section uses a PIN receiver and the transmitter uses 1310 nm FP laser, up to 15dB link budget ensure this module 1000Base Ethernet 20Km application.

● **Absolute Maximum Ratings**

Parameter	Symbol	Min.	Typical	Max.	Unit
Storage Temperature	T <sub>S</sub>	-40		+85	°C
Supply Voltage	V <sub>CC</sub>	-0.5		4	V
Relative Humidity	RH	0		85	%

● **Recommended Operating Environment:**

Parameter	Symbol	Min.	Typical	Max.	Unit
Case operating Temperature	T <sub>C</sub>				°C
		Commercial	0	70	
Supply Voltage	V <sub>CC,T,R</sub>	3.0		3.6	V

● **Electrical Characteristics (T<sub>OP</sub> = T<sub>C</sub>, V<sub>CC</sub> = 3.0 to 3.60 Volts)**

Parameter	Symbol	Min.	Typical	Max.	Unit	Note
Supply Voltage	V <sub>CC</sub>	3.00	3.30	3.60	V	
Supply Current	I <sub>CC</sub>		130	250	mA	
Inrush Current	I <sub>surge</sub>			I <sub>CC</sub> +30	mA	
Maximum Power	P <sub>max</sub>			1.0	W	
<b>Transmitter Section:</b>						
Input differential impedance	R <sub>in</sub>	90	100	110		1
Single ended data input swing	V <sub>in PP</sub>	200		1200	mVp-p	
Transmit Disable Voltage	V <sub>D</sub>	V <sub>CC</sub> – 1.3		V <sub>CC</sub>	V	2
Transmit Enable Voltage	V <sub>EN</sub>	V <sub>EE</sub>		V <sub>EE</sub> + 0.8	V	
Transmit Disable Assert Time	T <sub>dessert</sub>			10	us	
<b>Receiver Section:</b>						
Single ended data output swing	V <sub>out,pp</sub>	250		1000	mv	3
Data output rise time	t <sub>r</sub>			260	ps	4
Data output fall time	t <sub>f</sub>			260	ps	4
LOS Fault	V <sub>losfault</sub>	V <sub>CC</sub> – 0.5		V <sub>CC,host</sub>	V	5
LOS Normal	V <sub>los norm</sub>	V <sub>EE</sub>		V <sub>EE</sub> +0.5	V	5
Power Supply Rejection	PSR	100			mVpp	6
Deterministic Jitter Contribution	RXΔDJ			51.7	ps	7
Total Jitter Contribution	RXΔTJ			122.4	ps	

Note:



**1.25G SFP Transceiver 1000BaseFX LR 1310nm**  
**(PN: MWS-12-31-10D / MWS-12-31-20D / MWS-12-31-40D)**

1. AC coupled.
2. Or open circuit.
3. Into 100 ohm differential termination.
4. 20 – 80 %
5. LOS is LVTTTL. Logic 0 indicates normal operation; logic 1 indicates no signal detected.
6. All transceiver specifications are compliant with a power supply sinusoidal modulation of 20 Hz to 1.5MHz up to specified value applied through the power supply filtering network shown on page 23 of the Small Form-factor Pluggable (SFP) Transceiver Multi-Source Agreement (MSA), September 14, 2000.
7. Measured with DJ-free data input signal. In actual application, output DJ will be the sum of input DJ and . DJ.

● **Optical Parameters**( $T_{OP} = T_c$ ,  $VCC = 3.00$  to  $3.60$  Volts)

Parameter	Symbol	Min.	Typical	Max.	Unit	Note
<b>Transmitter Section:</b>						
Center Wavelength	$\lambda_c$	1270	1310	1360	nm	1
Spectral Width	$\sigma$			3	nm	
Optical Output Power	$P_{out}$	-9		-3	dBm	2
Optical Rise/Fall Time	$t_r / t_f$			260	ps	3
Extinction Ratio	ER	9			dB	
Deterministic Jitter Contribution	TX $\Delta$ DJ			56.5	ps	4
Total Jitter Contribution	TX $\Delta$ TJ			119	ps	
Eye Mask for Optical Output	Compliant with Eye Mask Defined in IEEE 802.3 standard					
<b>Receiver Section:</b>						
Optical Input Wavelength	$\lambda$	1260		1360	nm	
Receiver Overload	$P_{ol}$	-3			dBm	5.6
RX Sensitivity	$S_{en}$			-24	dBm	5.6
RX_LOS Assert	LOS <sub>A</sub>	-40			dBm	
RX_LOS Deassert	LOS <sub>D</sub>			-25	dBm	
RX_LOS Hysteresis	LOS <sub>H</sub>	0.5			dB	
<b>General Specifications</b>						
Data Rate	BR		1250		Mb/s	
Bit Error Rate	BER			$10^{-12}$		
Max. Supported Link Length on 9/125 $\mu$ m SMF@1.25G	LMAX		20		km	7
Total System Budget	LB	15			dB	

Note

1. Also specified to meet curves in FC-PI 13.0 Figures 18 and 19, which allow trade-off between wavelength spectral width.
2. Class 1 Laser Safety per FDA/CDRH and EN (IEC) 60825 regulations.



**1.25G SFP Transceiver 1000BaseFX LR 1310nm**  
**(PN: MWS-12-31-10D / MWS-12-31-20D / MWS-12-31-40D)**

3. Unfiltered, 20-80%. Complies with IEEE 802.3 (Gig. E), FC 1x and 2x eye masks when filtered.
4. Measured with DJ-free data input signal. In actual application, output DJ will be the sum of input DJ and . DJ.
5. Measured with conformance signals defined in FC-PI 13.0 specifications.
6. Measured with PRBS 2<sup>7</sup> -1at 10<sup>-12</sup> BER
7. Dispersion limited per FC-PI Rev. 13

● **Digital Diagnostic Monitor Characteristics**

The following digital diagnostic characteristics are defined over the Recommended Operating Environment unless otherwise specified. It is compliant to SFF8472 Rev10.2 with internal calibration mode. For external calibration mode please contact our sales staff.

Parameter	Symbol	Min.	Max.	Unit
Temperature monitor absolute error	DMI_Temp	-3	3	degC
Laser power monitor absolute error	DMI_TX	-3	3	dB
RX power monitor absolute error	DMI_RX	-3	3	dB
Supply voltage monitor absolute error	DMI_VCC	-0.1	0.1	V
Bias current monitor	DMI_Ibias	-10%	10%	mA

● **Pin Assignment:**

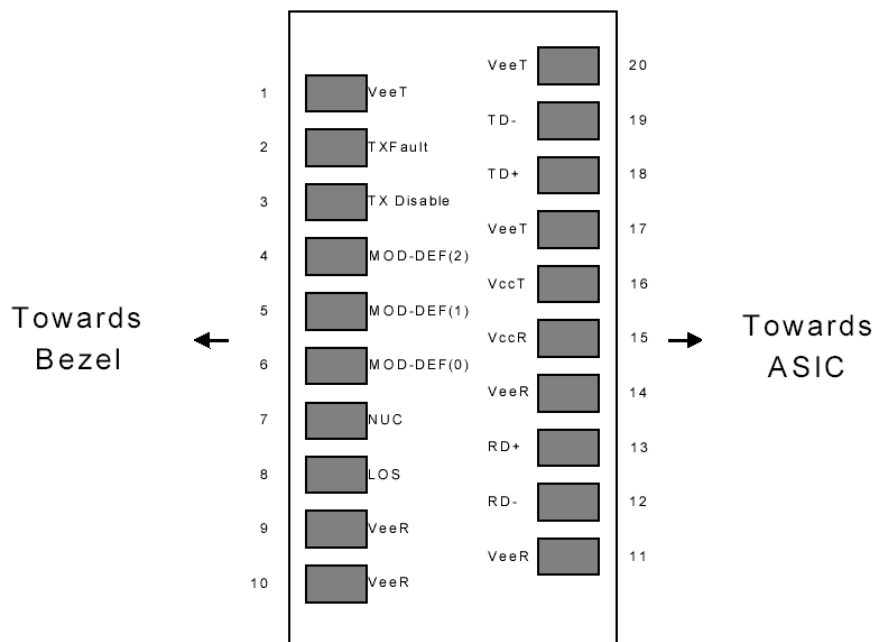

**Figure2:Diagram of Host Board Connector Block Pin Numbers and Names**



**1.25G SFP Transceiver 1000BaseFX LR 1310nm**  
(PN: MWS-12-31-10D / MWS-12-31-20D / MWS-12-31-40D)

● **Pin Description:**

Pin No	Name	Function	Plug Seq	Notes
1	VeeT	Transmitter Ground	1	1
2	TX Fault	Transmitter Fault Indication	3	
3	TX Disable	Transmitter Disable	3	2
4	MOD-DEF2	Module Definition	2	3
5	MOD-DEF1	Module Definition 1	3	3
6	MOD-DEF0	Module Definition 0	3	3
7	Rate Select	Not Connected	3	4
8	LOS	Loss of Signal	3	5
9	VeeR	Receiver Ground	1	1
10	VeeR	Receiver Ground	1	1
11	VeeR	Receiver Ground		1
12	RD-	Inv. Received Data Out	3	6
13	RD+	Received Data Out	3	6
14	VeeR	Receiver Ground	3	1
15	VccR	Receiver Power	2	1
16	VccT	Transmitter Power	2	
17	VeeT	Transmitter Ground	1	
18	TD+	Transmit Data In	3	6
19	TD-	Inv. Transmit In	3	6
20	VeeT	Transmitter Ground	1	

**Notes:**

1. Circuit ground is internally isolated from chassis ground.
2. Laser output disabled on TDIS >2.0V or open, enabled on TDIS <0.8V.
3. Should be pulled up with 4.7k - 10 kohms on host board to a voltage between 2.0V and 3.6V. MOD\_DEF(0) pulls line low to indicate module is plugged in.
4. Rate select is not used
5. LOS is open collector output. Should be pulled up with 4.7k – 10 kohms on host board to a voltage between 2.0V and 3.6V. Logic 0 indicates normal operation; logic 1 indicates loss of signal.
6. AC Coupled

● **SFP Module EEPROM Information and Management**

The SFP modules implement the 2-wire serial communication protocol as defined in the SFP -8472. The serial ID information of the SFP modules and Digital Diagnostic Monitor parameters can be accessed through the I<sup>2</sup>C interface at address A0h and A2h.

The memory is mapped in Table 1.

Detailed ID information (A0h) is listed in Table 2.

And the DDM specification at address A2h.



**1.25G SFP Transceiver 1000BaseFX LR 1310nm**  
 (PN: MWS-12-31-10D / MWS-12-31-20D / MWS-12-31-40D)

For more details of the memory map and byte definitions, please refer to the SFF-8472, “Digital Diagnostic Monitoring Interface for Optical Transceivers”. The DDM parameters have been internally calibrated.

**Table 1.** Digital Diagnostic Memory Map (Specific Data Field Descriptions)

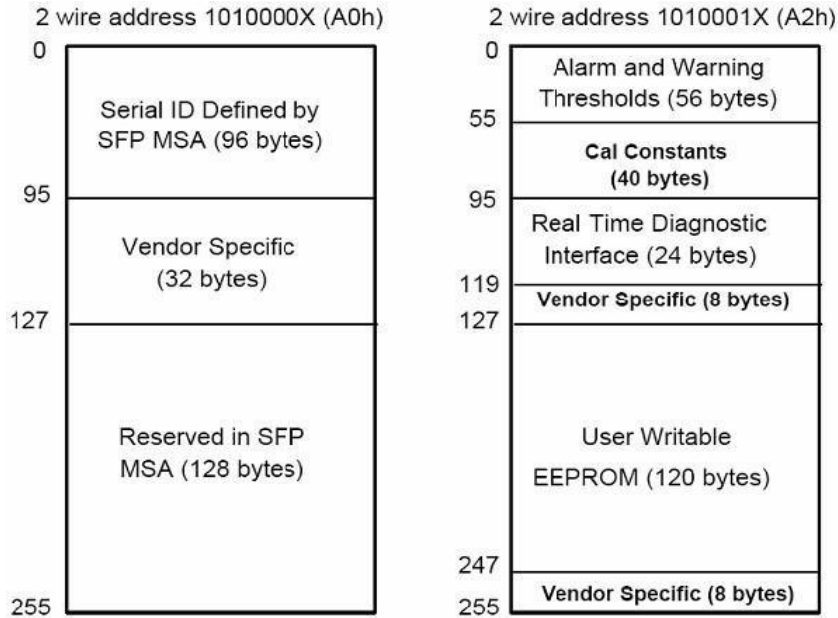

● - EEPROM Serial ID Memory Contents (A0h)

Data Address	Length (Byte)	Name of Length	Description and Contents
Base ID Fields			
0	1	Identifier	Type of Serial transceiver (03h=SFP)
1	1	Reserved	Extended identifier of type serial transceiver (04h)
2	1	Connector	Code of optical connector type (07=LC)
3-10	8	Transceiver	Gigabit Ethernet 1000Base-LX
11	1	Encoding	8B/10B (01h)
12	1	BR,Nominal	Nominal baud rate, unit of 100Mbps
13	1	Reserved	(0000h)
14	1	Length(9um,km)	Link length supported for 9/125um fiber, units of km
15	1	Length(9um)	Link length supported for 9/125um fiber, units of 100m
16	1	Length(50um)	Link length supported for 50/125um fiber, units of 10m
17	1	Length(62.5um)	Link length supported for 62.5/125um fiber, units of 10m



**1.25G SFP Transceiver 1000BaseFX LR 1310nm**  
**(PN: MWS-12-31-10D / MWS-12-31-20D / MWS-12-31-40D)**

18	1	Length(Copper)	Link length supported for copper, units of meters
19	1	Reserved	
20-35	16	Vendor Name	SFP vendor name:
36	1	Reserved	
37-39	3	Vendor OUI	SFP transceiver vendor OUI ID
40-55	16	Vendor PN	Part Number: "OPxxxxx" (ASCII)
56-59	4	Vendor rev	Revision level for part number
60-61	2	Wavelength	Laser wavelength
62	1	Reserved	
63	1	CCID	Least significant byte of sum of data in address 0-62
Extended ID Fields			
64-65	2	Option	Indicates which optical SFP signals are implemented(001Ah = LOS, TX_FAULT, TX_DISABLE all supported)
66	1	BR, max	Upper bit rate margin, units of %
67	1	BR, min	Lower bit rate margin, units of %
68-83	16	Vendor SN	Serial number (ASCII)
84-91	8	Date code	Manufacturing date code
92	1	Diagnostic Type	Diagnostics
93	1	Enhanced Options	Diagnostics
94	1	SFF-8472	Diagnostics
95	1	CCEX	Check code for the extended ID Fields (addresses 64 to 94)
Vendor Specific ID Fields			
96-127	32	Readable	Vendor specific date, read only
128-255	128	Reserved	Reserved for SFF-8079

● **Digital Diagnostic Monitor Characteristics**

Data Address	Parameter	Accuracy	Unit
96-97	Transceiver Internal Temperature	±3.0	°C
98-99	VCC3 Internal Supply Voltage	±3.0	%
100-101	Laser Bias Current	±10	%
102-103	Tx Output Power	±3.0	dBm
104-105	Rx Input Power	±3.0	dBm

● **Regulatory Compliance**

MWS-12-31-XX complies with international Electromagnetic Compatibility (EMC) and international safety requirements and standards (see details in Table following).

Electrostatic Discharge (ESD) to the Electrical Pins	MIL-STD-883E Method 3015.7	Class 1(>1000 V)
--	----------------------------	------------------



**1.25G SFP Transceiver 1000BaseFX LR 1310nm**  
 (PN: MWS-12-31-10D / MWS-12-31-20D / MWS-12-31-40D)

Electrostatic Discharge (ESD) to the Duplex LC Receptacle	IEC 61000-4-2 GR-1089-CORE	Compatible with standards
Electromagnetic Interference (EMI)	FCC Part 15 Class B EN55022 Class B (CISPR 22B) VCCI Class B	Compatible with standards
Laser Eye Safety	FDA 21CFR 1040.10 and 1040.11 EN60950, EN (IEC) 60825-1,2	Compatible with Class 1 laser product.

● **References**

1. IEEE Std 802.3, 2002 Edition, Clause 38, PMD Type 1000BASE-LX. IEEE Standards Department, 2002.
2. “Fibre Channel Physical and Signaling Interface (FC-PH, FC-PH2, FC-PH3)”. American National Standard for Information Systems.
3. “Fibre Channel Draft Physical Interface Specification (FC-PI 13.0)”. American National Standard for Information Systems.
4. Small Form-factor Pluggable (SFP) Transceiver Multi-source Agreement (MSA) September 14, 2000.

● **Recommended Circuit:**

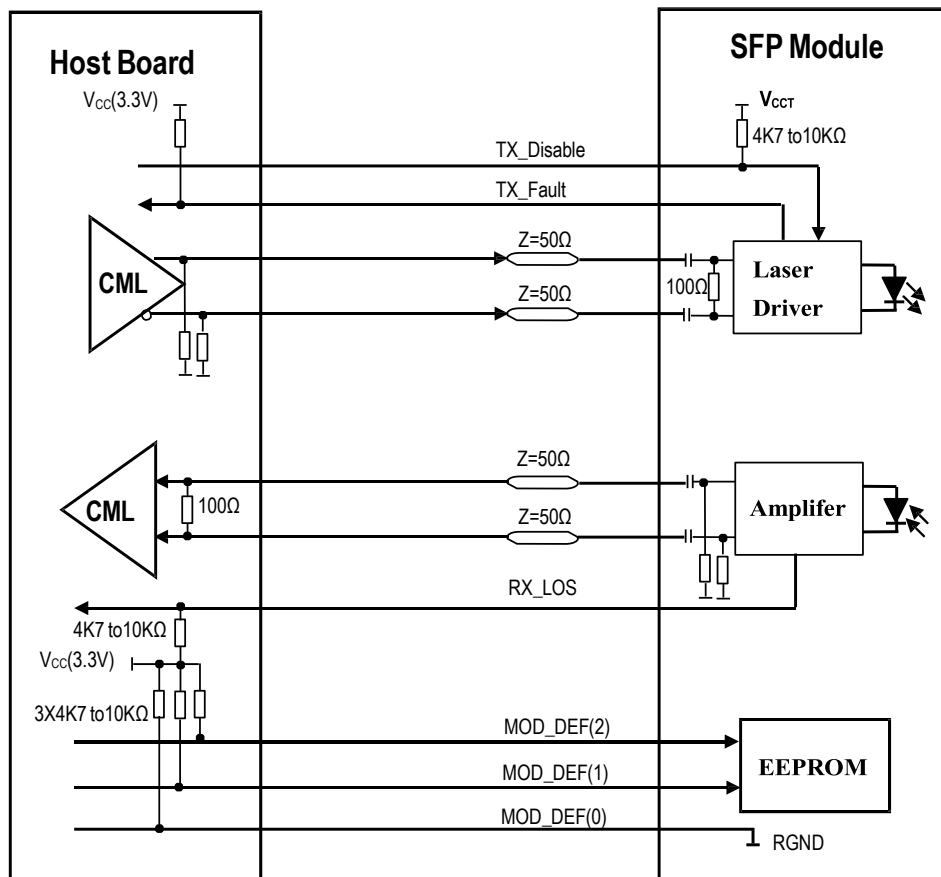

**Figure 5. SFP Host Recommended Circuit**





**1.25G SFP Transceiver 1000BaseFX LR 1310nm**  
 (PN: MWS-12-31-10D / MWS-12-31-20D / MWS-12-31-40D)

● **Mechanical Dimensions:**

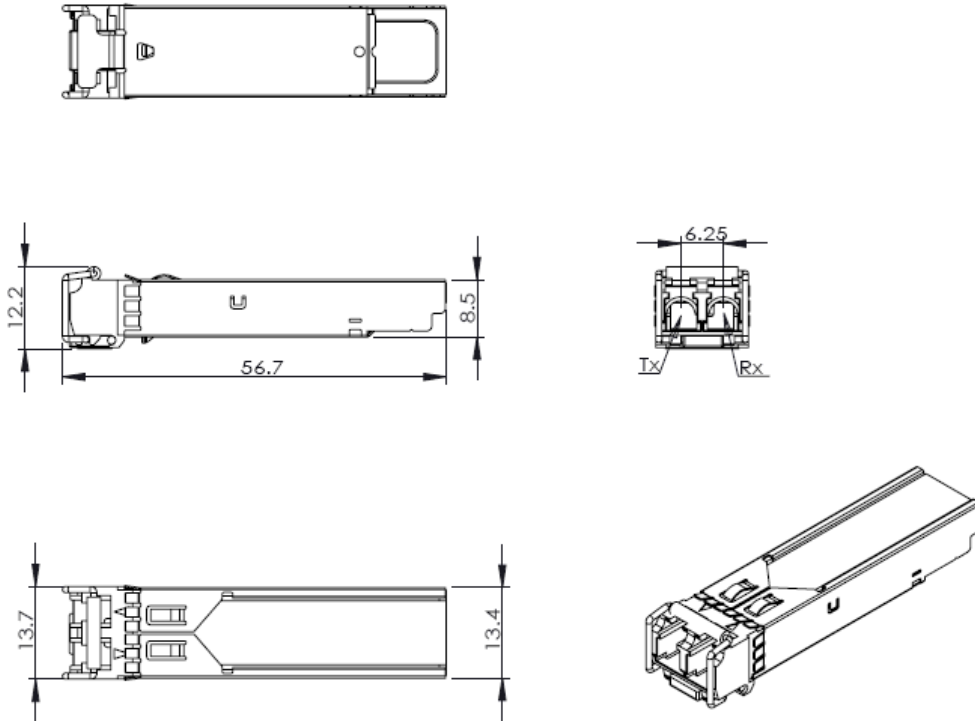

**Figure 6. Mechanical Drawing**

**Order Information:**

PN	Parameter	Unit
MWS-12-31-10D	1.25G SF SM 1310nm LC duplex 10Km DDM	PCS
MWS-12-31-20D	1.25G SF SM 1310nm LC duplex 20Km DDM	PCS
MWS-12-31-40D	1.25G SF SM 1310nm LC duplex 40Km DDM	PCS

UPCOM reserves the right to make changes to the products or information contained herein without notice. No liability is assumed as a result of their use or application. No rights under any patent accompany the sale of any such products or information.

Published by UPCOM Communication Co., Ltd.