

# IES6312 Series Managed Industrial PoE/non-PoE Ethernet Switch Quick Installation Guide

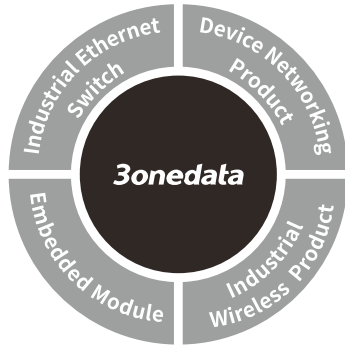

3onedata Co., Ltd.

Address: 3/B, Zone 1, Baiwangxin High Technology Industrial Park, Xili, Nanshan District, Shenzhen

Website: www.3onedata.com

Tel: +86 0755-26702688

Fax: +86 0755-26703485

## 【Package Checklist】

Please check whether the package and accessories are intact while using the switch for the first time. The following list is the standard configuration; please follow up the real product.

1. Industrial Ethernet switch
2. CD
3. Quick installation guide
4. Warranty card
5. Certification

If any of these items are damaged or lost, please contact our company or dealers, we will solve it ASAP.

## 【Product Overview】

The series are managed DIN-Rail industrial PoE/non-PoE Ethernet switches. Module as follows:

Model I IES6312-8GP4GF-2P24-120W(8 Gigabit PoE ports + 4 Gigabit fiber ports, 24VDC PoE, PoE power of 120W)

Model II IES6312-8GP4GS-2P24-120W(8 Gigabit PoE ports + 4 Gigabit SFP slots, 24VDC PoE, PoE power of 120W)

Model III IES6312-8GP4GF-2P48-120W(8 Gigabit PoE ports + 4 Gigabit fiber ports, 48VDC PoE, PoE power of 120W)

Model IV IES6312-8GP4GS-2P48-120W(8 Gigabit PoE ports +4 Gigabit SFP slots, 48VDC PoE, PoE power of 120W)

Model V IES6312-8GP4GF-2P48-240W(8 Gigabit PoE ports + 4 Gigabit fiber ports, 48VDC PoE, PoE power of 240W)

Model VI IES6312-8GP4GS-2P48-240W(8 Gigabit PoE ports + 4 Gigabit SFP slots, 48VDC PoE, PoE power of 240W)

Model VII IES6312-8GT4GF-2P48(8 Gigabit copper ports + 4 Gigabit fiber ports, 12~48VDC)

Model VIII IES6312-8GT4GS-2P48(8 Gigabit copper ports + 4 Gigabit SFP slots, 12~48VDC)

Model IX IES6312-8GT4GF-P220(8 Gigabit copper ports + 4 Gigabit fiber ports, 100~240VAC)

Model X IES6312-8GT4GS-P220(8 Gigabit copper ports + 4 Gigabit SFP slots, 100~240VAC)

## 【Panel Design】

➤ Top view, Bottom view and Rear view

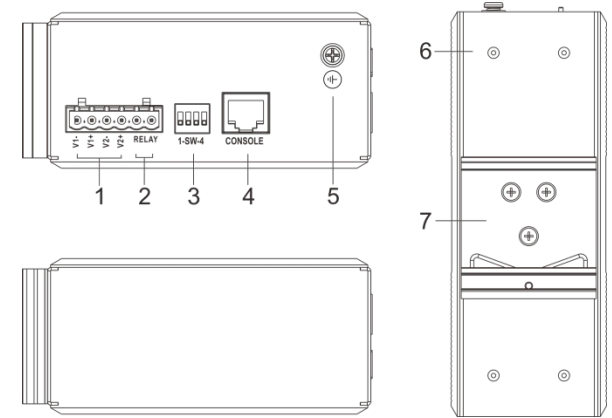

➤ Front view

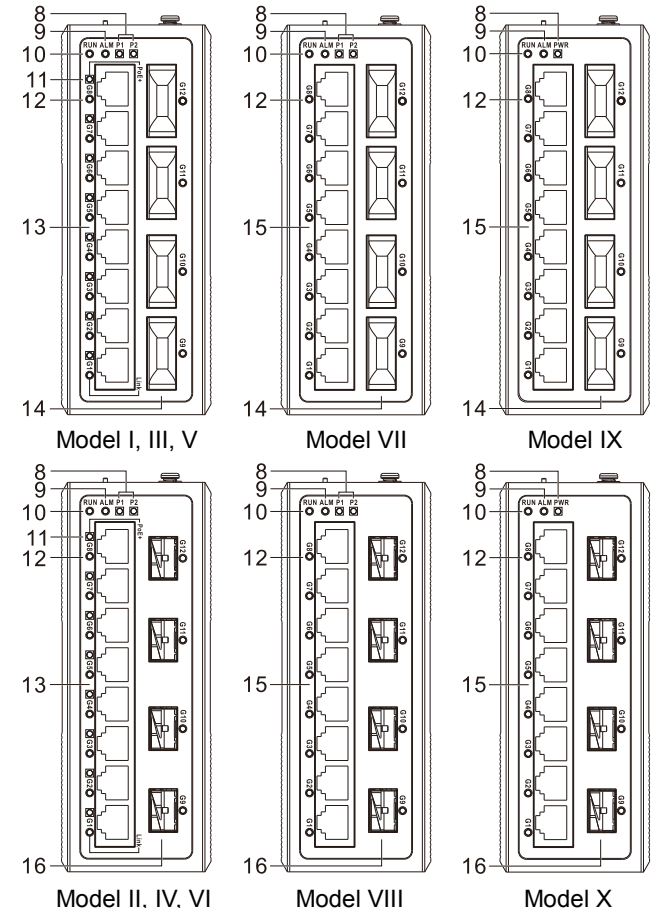

1. Power input terminal block
2. Relay alarm output terminal block

3. DIP switch
4. Console port
5. Grounding screw
6. Wall mounting screw hole
7. DIN-Rail mounting kit
8. Power supply indicator P1/P2/PWR
9. Relay alarm indicator ALM
10. Device running indicator RUN
11. PoE indicator PoE+
12. Interface connection indicator Link
13. Gigabit PoE port
14. Gigabit fiber port
15. Gigabit copper port
16. Gigabit SFP slot

### 【Mounting Dimension】

Unit: mm

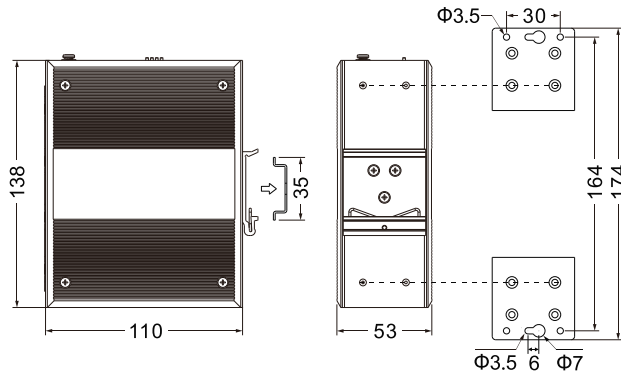

#### Notice:

The hanging panel accessories on the right side of the picture above need additional purchase.



#### Attention before mounting:

- Don't place or install the device in area near water or moist, keep the relative humidity of the device surrounding between 5%~95% without condensation.
- Before power on, first confirm the supported power supply specification to avoid over-voltage damaging the

device.

- The device surface temperature is high after running; please don't directly contact to avoid scalding.

### 【DIN-Rail Mounting】

For convenient usage in industrial environments, the product adopts 35mm DIN-Rail mounting, mounting steps as below:

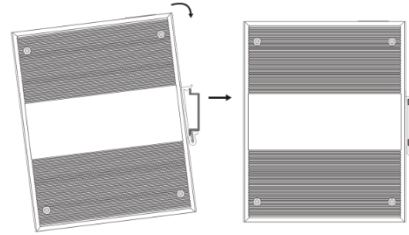

- Step 1 Check if the DIN-Rail mounting kit is installed firmly.
- Step 2 Insert the bottom of DIN-Rail mounting kit (one side with spring support) into DIN-Rail, and then insert the top into DIN-Rail.  
Tips:  
Insert a little to the bottom, lift upward and then insert to the top.
- Step 3 Check and confirm the product is firmly installed on DIN-Rail, then mounting ends.

### 【Disassembling DIN-Rail】

- Step 1 Device power off.
- Step 2 After lift the device upward slightly, first shift out the top of DIN-Rail mounting kit, then shift out the bottom of DIN-Rail, disassembling ends.



#### Attention before power on:

- Power ON operation: first connect power line to the connection terminal of device power supply, then power on.
- Power OFF operation: first unpin the power plug, then remove the power line, please note the operation order above.

### 【Power Supply Connection】

- DC power supply

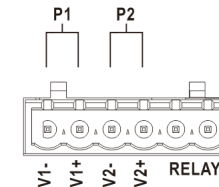

The series provide 6-pin 5.08mm pitch terminal blocks, and two independent DC power supply systems of PWR1 and PWR2. PIN1-PIN4 are used for power supply input. This series provide 8 types of product and adopt 4 different power supply ranges. Please be aware of the corresponding power supply type of the device lest damaging the device.

#### 24VDC PoE device

The power supply of 24VDC PoE device model I and model II has built-in 12A over-current protection, and support anti-reverse connection and redundant backup. Input power is 24VDC.

#### 48VDC PoE device

The power supply of 48VDC PoE device model III, model IV, model V and model VI has built-in 5A over-current protection, and support anti-reverse connection and redundant backup. Input power is 48VDC.

#### 12~48VDC non-PoE device

The power supply of 12~48VDC non-PoE device model VII and model VIII has built-in 3A over-current protection, and support non-polarity and redundant backup. Input power range is 12~48VDC.

#### ➢ AC power supply



This series provide 6 pins 5.08mm pitch terminal blocks and AC power supply system.

#### 220VAC non-PoE device

The power supply of 220VAC non-PoE device model IX and model X has built-in 5A over-current protection. Input power range is 100~240VAC.

### 【Relay Connection】

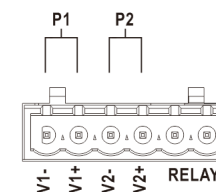

This series of products provide 6-pin 5.08mm pitch terminal blocks. Relay terminals are a pair of normally open contacts in device alarm relay. They are open circuit in normal non alarm state, closed when any alarm

information occurs. Such as: it's closed when power off, and send out alarm. This series switches support 1 channel relay alarm information output, support DC power alarm information or network abnormal alarm output, it can be connected to alerting lamp, alarm buzzer, or other switching value collecting devices to warn operators timely when alarm information occurs.

### 【DIP Switch Setting】



Provide 4-bits DIP switch for function setting, where "ON" is enable valid terminal. DIP switch define as follows:

DIP	Definition	Operation
1	Restore factory setting	When it is set to ON, the device will reboot and restore to factory setting automatically. Then pull it back.
2	Reserved	-
3	Reserved	-
4	Reserved	-

### 【Console Port Connection】

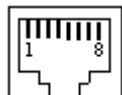

The device provides 1 program debugging port based on RS232 serial port. The interface adopts RJ45 port, and can conduct device CLI command line management after connecting to PC.

PIN	2	3	5
Definition	TXD	RXD	GND

### 【Checking LED Indicator】

This device provides LED indicators to monitor device's operating state, which has simplified the troubleshooting process comprehensively. The status of each LED is described in the table below:

LED	Status	Description
RUN	ON	The device is powered on or the device is abnormal.
	OFF	The device is powered off or the device is abnormal.
	Blinking	Blink 1 time/s, the device runs

		normally
ALM	ON	DC Power supply, port failure alarm
	OFF	Relay alarm is turned off or has no alarm
P1/P2/PWR	ON	Power supply P1/P2/PWR is connected and running normally
	OFF	Power supply P1/P2/PWR is disconnected and running abnormally
Link G1-G12	ON	Ethernet port has established valid network connection
	Blinking	Ethernet port is in active status
	OFF	Ethernet port has not established valid network connection
POE G1-G8	ON	PD device is powered over PoE port normally
	OFF	PD device is not powered over PoE or not connected to PoE

### 【Logging in to WEB Interface】

This device supports WEB management and configuration. Computer can access the device via Ethernet interface. The way of logging in to device's configuration interface via IE browser is shown as below:

Step 3 Configure the IP addresses of computer and the device to the same network segment, and the network between them can be mutually accessed.

Step 4 Enter device's IP address in the address bar of the computer browser.

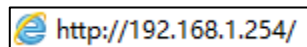

Step 5 Enter device's username and password in the login window as shown below.



Step 6 Click "OK" button to login to the WEB interface of the device.



#### Note:

- The default IP address of the device is "192.168.1.254".
- The default username and password of the device is "admin".
- If the username or password is lost, user can restore it to factory settings via device DIP switch or management software; all modified configurations will be cleared after restoring to factory settings, so please backup configuration file in advance.
- Please refer to user manual for specific configuration method of logging in to WEB interface and other configurations about network management function.

### 【Specification】

Panel	
Gigabit PoE port	10/100/1000Base-T(X), RJ45, automatic flow rate control, full/half duplex mode, MDI/MDI-X autotuning; PoE power supply pins: V+, V+, V-, V-. Output power is 30W

Gigabit copper port	10/100/1000Base-T(X), RJ45, automatic flow rate control, full/half duplex mode, MDI/MDI-X autotuning
Gigabit fiber port	1000Base-FX, optional SC/ST/FC interface
Gigabit SFP slot	1000Base-SFP, LC
Console port	CLI commend line management port(RS-232), RJ45
Alarm port	6-pin 5.08mm pitch terminal blocks (relay occupies 2 pins), support 1 relay alarm output, current load capacity is 1A@30VDC or 0.3A@125VAC
Indicator	Power indicator, run indicator, interface connection indicator, alarm indicator and PoE indicator
<b>Switch property</b>	
Backplane bandwidth	24G
Buffer size	4Mbit
MAC address table	8K
<b>Power supply</b>	
Model I, Model II	24VDC PoE, anti-reverse connection, redundant backup, built-in 12A over-current protection
Model III, Model IV, Model V, Model VI	48VDC PoE, anti-reverse connection, redundant backup, built-in 5A over-current protection
Model VII, Model VIII	12~48VDC, non-polarity, redundant backup, built-in 3A over-current protection

Model IX, Model X	100~240VAC, built-in 5A over-current protection
Terminal block	6-pin 5.08mm pitch terminal blocks, power supply occupies 4 pins
<b>Power consumption</b>	
Model I	No-load: 9.1W@24VDC Full-load: 141.5W@24VDC
Model II	No-load: 6.0W@24VDC Full-load: 100.8W@24VDC
Model III	No-load: 8.8W@48VDC Full-load: 130.0W@48VDC
Model IV,	No-load: 5.2W@48VDC Full-load: 132.9W@48VDC
Model V	No-load: 8.8W@48VDC Full-load: 199.6W@48VDC
Model VI	No-load: 5.2W@48VDC Full-load: 200.2W@48VDC
Model VII	No-load: 7.5W@24VDC Full-load: 10.5W@24VDC
Model VIII	No-load: 4.2W@24VDC Full-load: 10.2W@24VDC
Model IX	No-load: 7.7W@220VAC Full-load: 11.1W@220VAC
Model X	No-load: 4.6W@220VAC Full-load: 10.4W@220VAC
<b>Operating environment</b>	
Operating temperature	-40~75℃
Storage temperature	-40~85℃
Operating humidity	5%~95% (no condensation)
Protection grade	IP40 (metal shell)