



## ICS6400-12GT12GS4XS

DIN-Rail Mounting

28-port Gigabit /10Gigabit Layer 3 Industrial Ethernet Switch

- Support 12 Gigabit copper ports + 12 Gigabit SFP slots + 4 10Gigabit SFP+ slots
- Adopt SW-Ring patented technology, support single ring, coupling ring, chain, Dual-homing, automatic recovery time of network failure < 20ms
- 10 Gigabit bandwidth can realize transmitting large amounts of video, voice and data with high performance and high speed
- Support dual power supply, input voltage: 12~48VDC
- Support -40~65°C wide operating temperature range



Industrial Grade



Fanless Design



RPS

## Introduction

ICS6400-12GT12GS4XS is 28-port Gigabit /10Gigabit Layer 3 Industrial Ethernet Switch. This product provides multiple interfaces including Gigabit copper ports, Gigabit SFP slots and 10G SFP slots. It adopts DIN-Rail mounting to meet the requirements of different application scenes. Abundant numbers of interfaces, bandwidth of Gigabit/10Gigabit combination and ability to transmit large amounts of video, voice and data with high performance and high speed meet the application requirements of large-scale industrial network.

The network management system supports various network protocols and industry standards, such as static routing, RIP, OSPF, ARP, VRRP, NAT, IGMP, PIM-SM, PIM-DM, STP/RSTP/MSTP, ERPS, 802.1Q VLAN, QoS, LLDP, IGMP Snooping, DHCP-Server/Snooping/Relay, port trunking, port mirroring, etc. It also possesses complete management functions, support port configuration, port statistics, network diagnosis, rapid configuration, online upgrade, etc.; CLI, WEB, Telnet, SNMP, SSH and other access methods can be supported. Network management system could bring you great user experience through its friendly interface design and easy and convenient operation.

DIP switch can achieve restore factory defaults of the device. When port has link failure, ALARM indicator will be bright and send out alarm, meanwhile, alarm device connected to the relay will send out alarm for rapid scene troubleshooting. The device input power supply has two inputs, which can ensure the normal operation of the device when one power supply fails. Hardware adopts fanless, low power consumption, wide temperature and voltage design and has passed rigorous industrial standard tests, which can suit for the industrial scene environment with harsh requirements for EMC. It can be widely used in smart grid, rail transit, smart city, safety city, new energy, intelligent manufacturing and other industrial fields.

## Features and Benefits

- ⊙ SNMPv1/v2c/v3 is used for network management of various levels
- ⊙ RMON can be used for efficient and flexible network monitoring
- ⊙ Port mirroring can conduct data analysis and monitoring, which is convenient for online debugging
- ⊙ QoS supports real-time traffic classification and priority setting
- ⊙ LLDP can achieve automatic topology discovery, which is convenient for visual management
- ⊙ DHCP server can be used for distributing IP address with different strategies
- ⊙ File management is convenient for the device rapid configuration and online upgrading
- ⊙ Port statistics can be used for the port real time traffic statistics
- ⊙ ARP could be used for MAC address resolution

- User password can conduct user hierarchical management to improve the device management security
- Storm suppression can restrain broadcast, unknown multicast and unicast
- SSH configuration guarantee secure access to data
- VLAN can be set to simplify network planning
- Port trunking can increase network bandwidth and enhance the reliability of network connection to achieve optimum bandwidth utilization
- Bandwidth management can reasonably distribute network bandwidth, preventing unpredictable network status
- Port isolation could achieve port isolation in the same VLAN and save VLAN resources
- PIM-DM/PIM-SM, IGMP Snooping and static multicast can be used to filter multicast data to save network bandwidth
- Ring, ERPS, STP/RSTP/MSTP can achieve network redundancy, preventing network storm
- Ping, Traceroute, Port Loopback and SFP Digital Diagnosis could achieve network diagnosis and troubleshooting
- VRRP, RIP, OSPF could implement dynamic router configuration
- Multicast routing can be transmitted across the VLAN and deal with multicast flow flexibly
- NAT maps private IP address to the legal IP address of external network, which can slow the consumption of IP address space
- Loop detection could efficiently eliminate the influence caused by port loopback by detecting the existence of loopback

## Dimension

Unit: mm

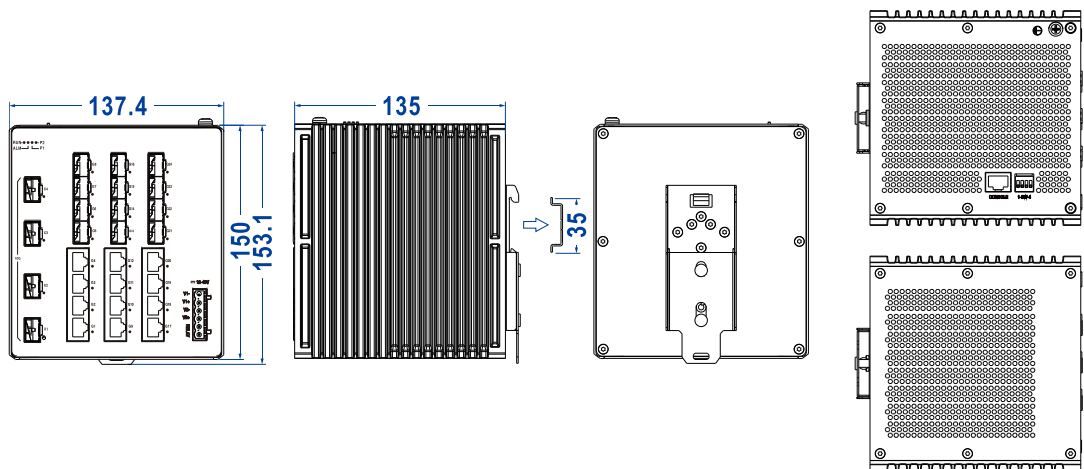

# Specification

<b>Standard &amp; Protocol</b>	<p>IEEE 802.3 for 10Base-T                  IEEE 802.3u for 100Base-TX                  IEEE 802.3ab for 1000Base-T                  IEEE 802.3z for 1000Base-X                  IEEE802.3ae for 10GBase-X                  IEEE 802.3x for Flow Control                  IEEE 802.1D for Spanning Tree Protocol                  IEEE 802.1w for Rapid Spanning Tree Protocol                  IEEE 802.1s for Multiple Spanning Tree Protocol                  IEEE 802.1Q for VLAN                  IEEE 802.1p for CoS                  IEEE 802.1AB for LLDP                  ITU-T G.8032 for ERPS</p>
<b>Management</b>	<p>SNMP v1/v2c/v3 Centralized Management of Equipment, RMON, Port Mirroring, QoS, LLDP, DHCP Server, DHCP Relay, File Management, Port Statistics, Log Information, Syslog Server, Static ARP</p>
<b>Security</b>	<p>Classification of User Permissions, NAT, Alarm Configuration, Storm Suppression, SSHD Configuration, Telnet Configuration, Loop Detection, Link Flapping Protection, HCP Snooping</p>
<b>Switch Function</b>	<p>802.1Q VLAN, Port Trunking, Bandwidth Management, Flow Control, Port Isolation</p>
<b>Unicast / Multicast</b>	<p>Static Multicast, IGMP, IGMP-Snooping, PIM-SM, PIM-DM</p>
<b>Redundancy Technology</b>	<p>Ring, STP/RSTP/MSTP, ERPS</p>
<b>Troubleshooting</b>	<p>Ping, Traceroute, Port Loopback, SFP Digital Diagnosis</p>
<b>Routing Technique</b>	<p>VRRP, RIP, OSPF, Multicast routing</p>
<b>Time Management</b>	<p>NTP</p>
<b>Interface</b>	<p>Gigabit copper port: 10/100/1000Base-T(X) self-adaptive RJ45, automatic flow control, support full/half duplex mode, MDI/MDI-X self-adaption                  Gigabit SFP Slot : 100/1000 Base-X self-adaption SFP slot                  10Gigabit SFP+: 1000/10G Base-X self-adaptive SFP+ slot                  Console port: CLI command line management port(RS-232), RJ45                  Alarm port: 6-pin 5.08mm pitch terminal blocks (2 pins for relay), support 1 relay alarm output</p>

Indicator	Running Indicator, Alarm Indicator, Power Supply Indicator, Interface Indicator
Switch Property	Transmission mode: store and forward MAC address: 16K Packet buffer size: 12Mbit Backplane bandwidth: 128G Switch time delay: <10μs
Power Supply	12~48VDC, 6-pin 5.08mm pitch terminal blocks. The power supply occupies 4 pins and supports dual power supply redundancy and anti-reverse connection.
Power Consumption	No-load: 15.4W@24VDC Full-load: 30W@24VDC
Working Environment	Operating temperature: -40~65°C Storage temperature: -40~85°C Relative humidity: 5%~95%(no condensation)
Physical Characteristic	Housing: IP30 protection, metal Installation: DIN-Rail mounting Dimension (W x H x D): 137.4mm×150mm×135mm Weight: 2kg
Industrial Standard	IEC 61000-4-2 (ESD, electrostatic discharge), Level 3 IEC 61000-4-4 (EFT, electrical fast transient pulses), Level 3 IEC 61000-4-5 (Surge), Level 3 Shock: IEC 60068-2-27 Free fall: IEC 60068-2-32 Vibration: IEC 60068-2-6
Authentication	CE, FCC, RoHS
Warranty	5 years

## Ordering Information

Available Models	Gigabit Copper Port	Gigabit SFP Slot	10Gigabit SFP+ Slot	Power Supply
ICS6400-12GT12GS4XS	12	12	4	12~48VDC dual power supply



Address: 3/B, Zone 1, Baiwangxin High Technology Industrial Park, Song Bai Road, Nanshan District, Shenzhen, 518108, China

TEL.: +86-755-26702668 ext 835      FAX: +86-755-26703485

E-mail: [ics@3onedata.com](mailto:ics@3onedata.com)

Website: [www.3onedata.com](http://www.3onedata.com)

◀ Please scan our QR code for more details

\*Product pictures and technical data in this datasheet are only for reference. Updates are subject to change without prior notice. The final interpretation right is reserved by 3onedata.